

## ZMGZ Series Force Measuring Journal

---

**10 times overload protection**

**No recalibration required**

---

**20 : 1 force measuring range**

**Wide measuring capability**

---

**Nominal forces from 100 – 3000 N**

**Sizes available for every application**

---

**Stainless steel sensor**

**Corrosion resistant, ultra durable**

---



### ● ZMGZ Series

The ZMGZ Series force measuring journals are used to measure the tension in continuous material processing lines. Force measuring journals are utilized with rollers that have an internal bearing. A bearing mounts to the bearing seat of the load cell and fits inside the roller. Thus the ZMGZ Series saves machine mounting space and providing a compact tension measuring roller assembly.

### ● Functional description

The ZMGZ Series force measuring journals utilize the flexion beam principle. When the Journal is subjected to a force, bending stress is applied to the measuring web. Four foil-type strain gauges in a full Wheatstone bridge configuration measure the bending and thus the material tension. The position of the red point depends on the application. If the force acts in the direction of the red point, positive values will result from the measuring amplifier output.

**ZMGZ Series • Dimensions in mm**

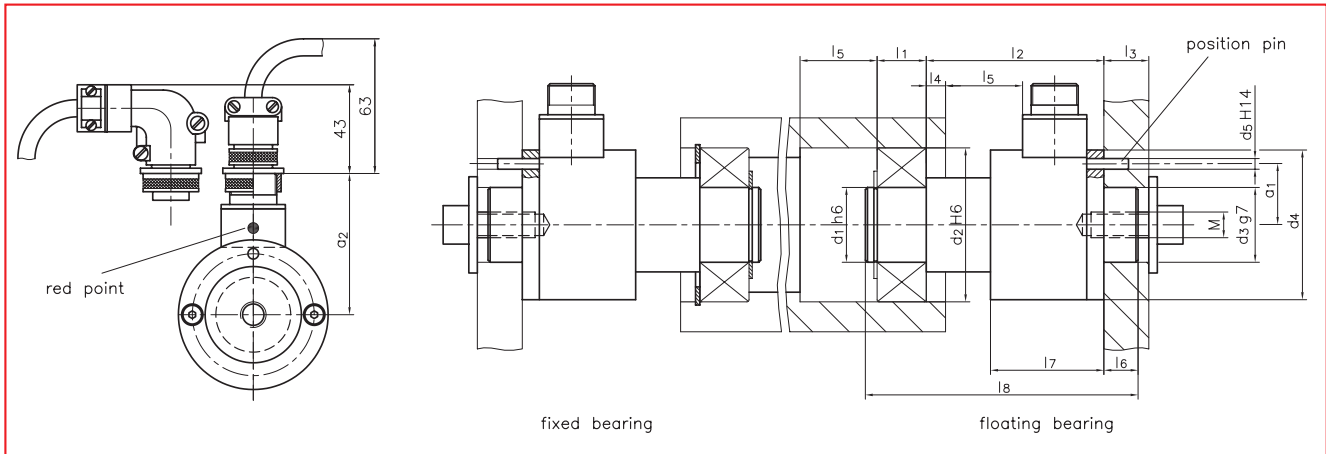

Rolling bearing types for ZMGZ205: 2205.2RS.TV or 63305.2RSR; Rolling bearing types for ZMGZ207: 2207.2RS.TV or 63307.2RSR

**ZMGZ Series • Specifications**

Sensor Type	Nominal force N	Dimensions mm															Weight kg	
		d1	d2	d3	d4	d5	l1	l2	l3	l4	l5	l6	l7	l8	M	a1		a2
ZMGZ205.100	100	25	52	30	50	4	18	68.5	15	9	23	10	43.5	100	M10	20	56	0.9
ZMGZ205.200	200																	
ZMGZ205.375	375																	
ZMGZ205.750	750																	
ZMGZ205.1500	1500																	
ZMGZ207.100	100	35	72	35	70	5	23	83	20	9	36	16	53	127.5	M12	28.5	67	1.9
ZMGZ207.200	200																	
ZMGZ207.375	375																	
ZMGZ207.750	750																	
ZMGZ207.1500	1500																	
ZMGZ207.3000	3000																	

**ZMGZ Series • Technical data**

<b>Sensitivity</b>	1.8 mV/V
<b>Tolerance of sensitivity</b>	< ± 0.2 %
<b>Accuracy class</b>	± 0.5 % (F <sub>nominal</sub> )
<b>Temperature coefficient</b>	± 0.1 % / 10 K
<b>Temperature range</b>	- 10...+ 60 °C
<b>Input resistance</b>	350 Ω
<b>Supply voltage</b>	1...12 VDC
<b>Maximum overload</b>	10 times rated nominal force
<b>Sensor material</b>	Stainless steel

**Options:**

- H14** = Right angle connector
- H15** = Connector opposite to the red point
- H16** = Temperature range up to 120 °C
- H18** = Straight waterproof connector
- H21** = Cable directly mounted, no connector
- H29** = Modified wiring and sealing for use in aggressive media (mostly acids)
- H30** = Modified wiring and sealing for use in hydrocarbon media (mostly oils and fuels)

**Order code (example):**

**ZMGZ205.375.H14.H16**

Sensor type

Options

**Scope of delivery:**

Electrical connector, mounting screw, washer, snap ring

**World Headquarters:**

**FMS Force Measuring Systems AG**  
 Aspstrasse 6  
 8154 Oberglatt (Switzerland)  
 Phone + 41 44 852 80 80  
 Fax + 41 44 850 60 06  
 info@fms-technology.com

**FMS USA, Inc.**  
 2155 Stonington Avenue  
 Suite 119  
 Hoffman Estates, IL 60169  
 Phone + 1 847 519 4400  
 Fax + 1 847 519 4401  
 fmsusa@fms-technology.com

**FMS UK**  
 Highfield, Atch Lench Road  
 Church Lench  
 Evesham WR 11 4UG  
 Phone + 44 1386 871023  
 Fax + 44 1386 871021  
 fmsuk@fms-technology.com

**FMS Italy**  
 Via Baranzate 67  
 20026 Novate Milanese  
 Phone + 39 02 39487035  
 Fax + 39 02 39487035  
 fmsit@fms-technology.com