

LMGZ Force Measuring Bearing

20 times overload protection

No recalibration required

50 : 1 force measuring range

Accuracy class 0.3 %

**Wide measuring capability
at high resolution**

Nominal forces from 33 N – 25 kN

Sizes available for every application

Stainless steel construction

Corrosion resistant



- **LMGZ Series**

The LMGZ series tension sensors offer the highest accuracy, reliability, and durability in the industry. Utilising a combination of stainless steel construction, a built in mechanical hard stop, and individual sensor performance verification, the LMGZ series sensors are perfect for all high performance running web applications.

- **Functional Description**

FMS Force Measuring Bearings are design to combine the live shaft bearings with the tension sensors to minimise machine space requirements. They can be mounted in any orientation directly to the machine frame or with supports. The red point on the outside of the sensor indicates the positive measuring direction. The high accuracy design ensures that even with low material wrap angles and high roller weights, tension can still be measured accurately.

Measuring Principle

Foil type strain gauges mounted in a full Wheatstone Bridge configuration in each sensor perform the actual tension measurement. The live shaft bearing applies the force to the measuring web in a parallel plane as opposed to a typical bending beam, thus ensuring maximum accuracy and

measuring sensitivity. A mechanical hardstop, which operates in both directions, ensures the highest overload protection and makes the sensor virtually indestructible. This combination guarantees the highest accuracy and reliability without the need for recalibration.

LMGZ Series • Schematic design

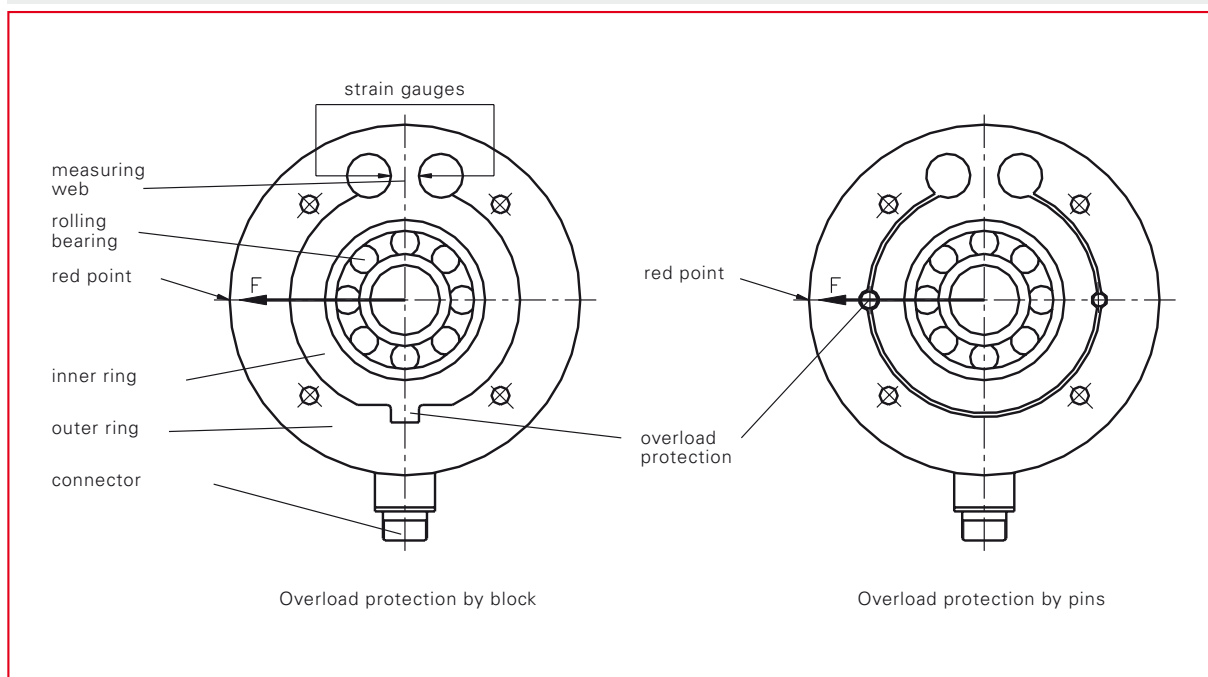

There are 2 design types of overload protection devices: block or pins.

LMGZ Series • Technical Data	
Sensitivity	1.8 mV / V
Tolerance of sensitivity	< $\pm 0.2\%$
Accuracy class	$\pm 0.3\%$ ($F_{nominal}$)
Temperature coefficient	$\pm 0.1\%$ / 10 K
Temperature range	-10...+ 60 °C (Option H16: -10...+120 °C)
Input resistance	350 Ω
Supply voltage	1...12 VDC
Overload protection	> 20 times the rated nominal force
Axial load	20 % Nominal force
Sensor material	Stainless steel

LMGZ Series • Dimensions in mm

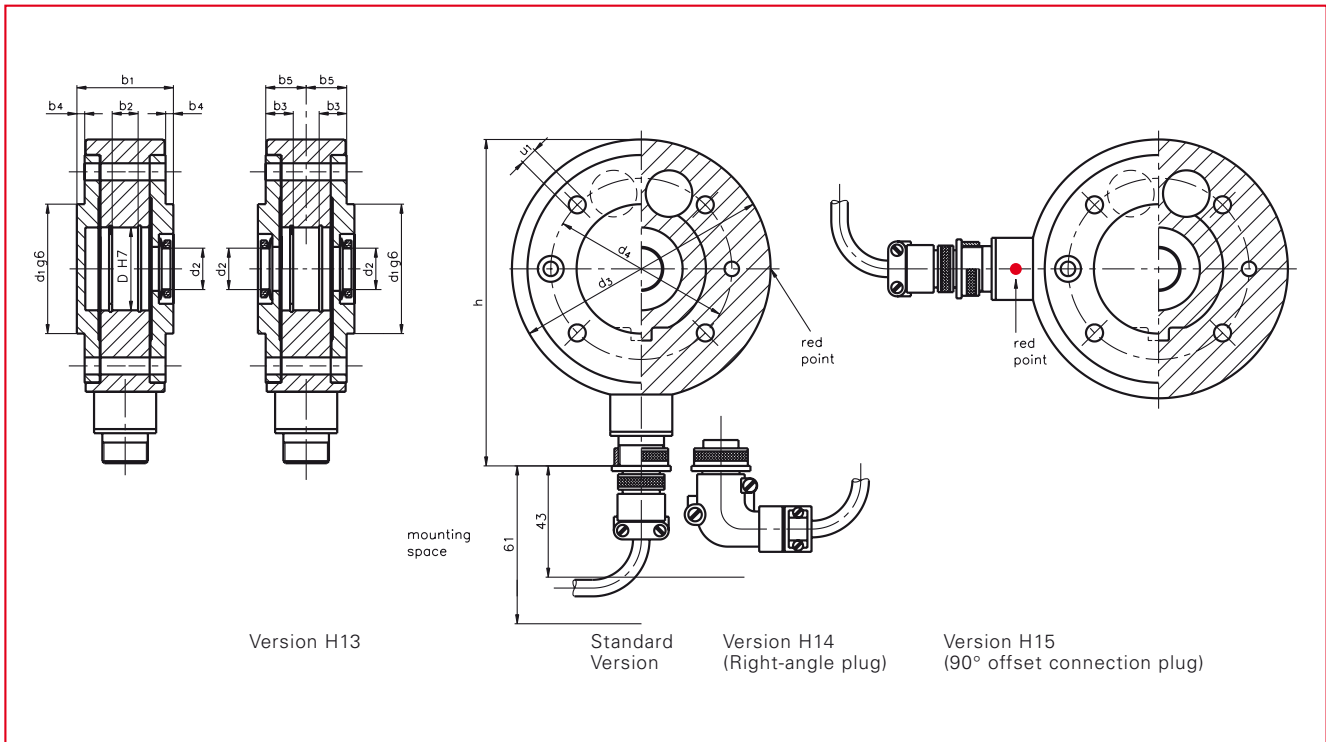

LMGZ Series • Nominal load / Dimensions

Bearing	Nominal force	Sensor	Dimensions in mm													De-flexion	Weight
			D	d1	d2	d3	d4	b1	b2	b3	b4	b5	h	u1			
∅ ¹⁾	N	Type	mm	mm	mm	mm	mm	mm	mm	mm	mm	mm	mm	mm	mm	mm	kg
9	100/50/33	LMGZ200	26	50	14	94	64	37	8	11.35	3	15.25	126.5	5.5	0.13	1.5	
12	500/250/125/50	LMGZ201	32	50	16	100	70	37	10	10.35	3	15.25	132	6.6	0.15	1.6	
17	1000/750/500 250/125/50	LMGZ203	40	60	22	105	75	37	12	9.35	3	15.25	137	6.6	0.15	1.7	
20 (standard) 25 (option)	1500/750/375/ 200/125	LMGZ205	52	70	31	125	95	48	15	12.2	4	19.6	157.5	6.6	0.20	2.9	
35 (standard) 40 (option)	3000/1500 750/375	LMGZ307	80	100	44 or 48	175	135	66	21	18.1	4	28.5	207.5	9	0.35	8.3	
50 (standard) 60 (option)	12.000 ²⁾ 6000 3000 1500 750 375	LMGZ310	110	130	64 or 70	225	175	76	27	20.1	4	33.5	258	11	0.10 0.52 0.30 0.30 0.30	15.0	
65 (standard) 80 (option)	25.000 ²⁾ 10.000 5000 2500	LMGZ313	140	160	80 or 90	270	220	81	33	19.6	4	36	303	11	0.10 0.95 0.60 0.50	22.5	

¹⁾ Indicate inner diameter of bearing when ordering ²⁾ Types available only in H15 version

LMGZ Series Options:

- H13** = Open covers on both sides
- H14** = Right angle connector
- H15** = 90° offset connection plug
- H16** = Temperature range of sensor with PG-gland
up to 150°C. Connectors up to 120°C
- H18** = Straight waterproof plug
- H19** = Grease nipple
- H21** = PG gland
- H29** = Modified wiring and sealing for use in aggressive
media
- H30** = For use in hydrocarbon media

Order code (example):



Lieferumfang:

Covers for both sides, 1 V ring seal, electrical connector, 1 snap ring.
Special versions for specific applications are available on request.

Bearings

Various types of bearings can be utilised with an LMGZ series sensor.
FMS recommends the use of self-aligning versions to compensate for shaft alignment errors and to avoid measuring inconsistencies.

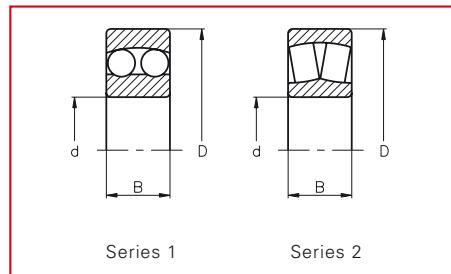

LMGZ Series • Bearings

Sensor	Suitable bearings (Bearings must be ordered separate)				
	Type	Series	Dimensions in mm		
			d	D	B
LMGZ200	129	1	9	26	8
LMGZ201	1201	1	12	32	10
LMGZ203	1203	1	17	40	12
LMGZ205	1304	1	20	52	15
	1205 ³⁾	1	25	52	15
LMGZ307	1307 ³⁾	1	35	80	21
	1208	1	40	80	18 ¹⁾
LMGZ310	1310 ³⁾	1	50	110	27
	2212	1	60	110	28 ²⁾
	21310	2	50	110	27
	22212	2	60	110	28 ²⁾
LMGZ313	1313 ³⁾	1	65	140	33
	2216	1	80	140	33
	21313	2	65	140	33
	22216	2	80	140	33

¹⁾ The difference $B - b_2$ is compensated for by washers ²⁾ Grind off 0.5 mm from each snap ring
³⁾ Standard bearings

GMGZ Series supports for LMGZ Series Sensors

When it is not conducive to mount the sensors directly onto the machine frame, the GMGZ Series supports are available for all sizes of LMGZ sensors. They are made of durable

cast iron and can either be supplied blank (customer drills the sensor mounting holes in them to optimise the positioning of the sensor) or with a 360° clock-wise pattern of

pre-drilled mounting holes. Mounting positions between $\alpha 1$ and $\alpha 2$ are not possible as the support foot interferes with the sensor connector.

GMGZ Series supports • Dimensions in mm

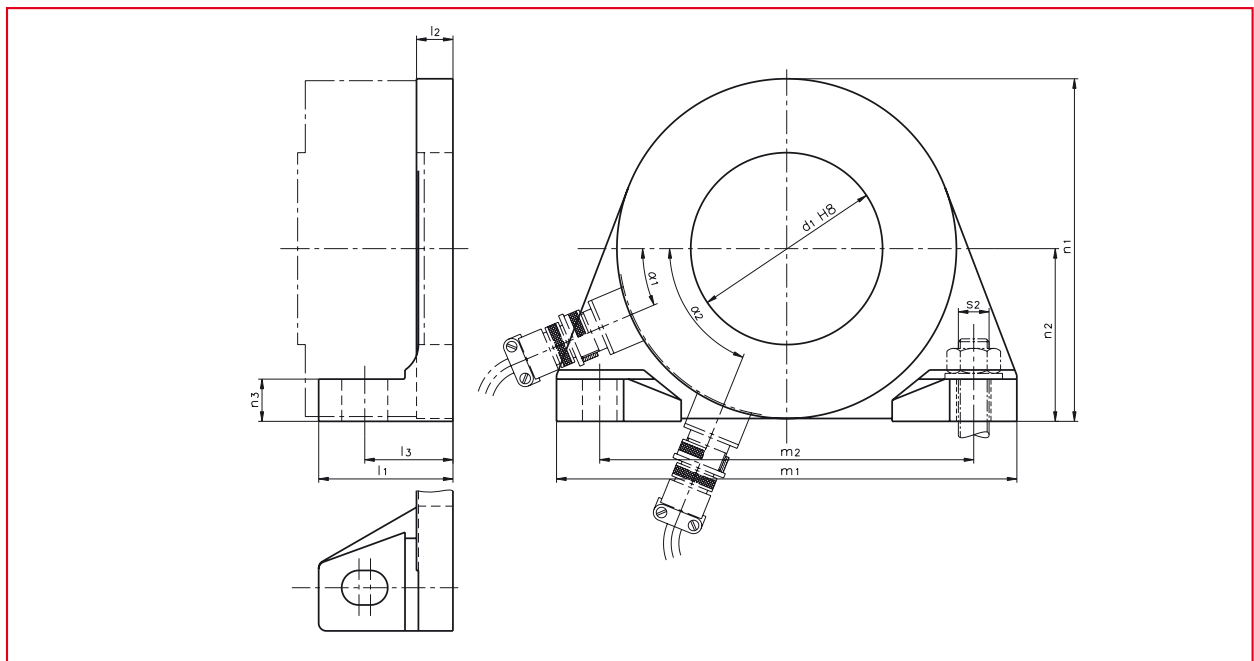

GMGZ Series • Mounting dimensions

Force sensor Type	Suitable support Type	Dimensions											Weight kg
		d1 mm	l1 mm	l2 mm	l3 mm	m1 mm	m2 mm	n1 mm	n2 mm	n3 mm	s2 mm	$\alpha 1 \dots \alpha 2$	
LMGZ200	GMGZ201	50	40	10	25.25	140	115	109	56	12	M8	17°...74°	0.92
LMGZ201	GMGZ201	50	40	10	25.25	140	115	109	56	12	M8	17°...74°	0.92
LMGZ203	GMGZ203	60	40	10	25.25	140	115	109	56	12	M8	17°...74°	0.91
LMGZ205	GMGZ205	70	45	13	32.75	170	140	130	67	16	M10	20°...69°	1.62
LMGZ307	GMGZ307	100	70	19	47.5	240	195	178	90	22	M16	22°...60°	6.41
LMGZ310	GMGZ310	130	90	24	57.5	290	240	232	118	28	M20	28°...65°	8.27
LMGZ313	GMGZ313	160	100	24	62.5	340	290	270	137	28	M20	28°...65°	11.1

FMS' Product Portfolio and System Solutions



The product line Force Sensors provides products, solutions and related services that increase industrial productivity, energy efficiency and high quality output. Its force sensors, tension measuring rollers and pillow block based designs are of premium quality and ultra durable.

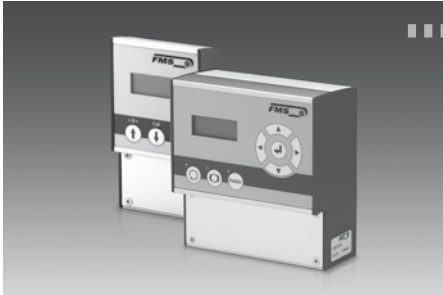

The product line Electronics facilitates tension monitoring, close loop tension control and web guiding systems. Key technologies include high-performance tension amplifiers and PID-controllers, as well as products to accurately and consistently control material position in continuously manufactured products.



The main focus of the FMS Web Guiding business is to provide customers with products and solutions for web detection and web positioning. Its steering frames, drives, controllers and material sensors provide an excellent coverage of the most important applications. The industries served include converting, printing, label processing and packaging.

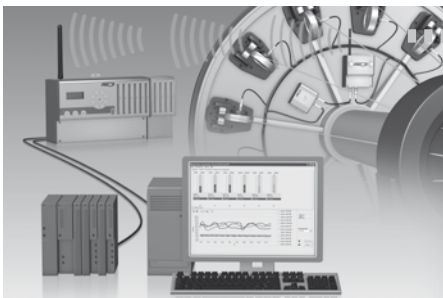

RTM (Radio Transmitted Tension Monitoring) delivers system solutions across the cable production value chain. These innovative systems utilise force measuring rollers to capture the tension of individual wires or strands, and then securely transmit this data from the rotating to the static part of the machine. The systems are designed with fully compatible components. Production rates and product quality on rotating strand-handling machinery are significantly improved.



Special Application Fields facilitates solutions in **vacuum** applications or in potentially explosive atmospheres. A sophisticated range of interface options including systems such as **PROFINET, Ethernet/IP, Profibus** and **CAN-bus** provide quick and efficient integration of FMS products into the existing communication and control infrastructure of your company.

World Headquarters:

FMS Force Measuring Systems AG
 Aspstrasse 6
 8154 Oberglatt (Switzerland)
 Phone + 41 44 852 80 80
 Fax + 41 44 850 60 06
 info@fms-technology.com

FMS USA, Inc.
 2155 Stonington Avenue
 Suite 119
 Hoffman Estates, IL 60169
 Phone + 1 847 519 4400
 Fax + 1 847 519 4401
 fmsusa@fms-technology.com

FMS UK
 Highfield, Atch Lench Road
 Church Lench
 Evesham WR 11 4UG
 Phone + 44 1386 871023
 Fax + 44 1386 871021
 fmsuk@fms-technology.com

FMS Italy
 Via Baranzate 67
 20026 Novate Milanese
 Phone + 39 02 39487035
 Fax + 39 02 39487035
 fmsit@fms-technology.com