

F 202 Series Force Measuring Sensor

Ultra Slim Design

Adaptable in machines with difficult space conditions

30 : 1 Force Measuring Range

Accurate measurements also at low loads

Accuracy Class 0.3 %

Highly linear measuring characteristic

Nominal Forces 50, 125, 250 and 500 N

Covers low and medium application range

Sensor body of stainless steel

Corrosion resistant, ultra durable



● F 202 Series

The F 202 Series Force Measuring Sensor is for use in live shaft roller applications where limited space is available. Their slim design provides a new option for accurate web tension measurement on machines where wider sensor designs simply did not fit. The high-performance F 202 Force Measuring Sensor ensures that even with low material wrap angles and high roller weights, tension will still be measured accurately. Their durability and operational reliability is excellent. The sensor is easily mounted to the machine side frame with two shoulder bolts. The red point located on the body of the sensor indicates the positive force measuring direction.

● Functional Description

The sensor utilizes foil type strain gauges mounted in a full Wheatstone Bridge configuration to provide extremely accurate tension measurement. The dual flexion beam design and built-in mechanical hard-stop eliminates angular deflection while reducing the possibility of recalibration or damage due to an overload condition. The connector on the sensor provides for faster wiring and installation, while the recommended self-aligning bearing accommodates limited roller misalignment. The F 202 Force Measuring Sensor is compatible with the full line of FMS Tension Measuring Amplifiers and Tension Controllers.

F202 Series • Dimensions in mm

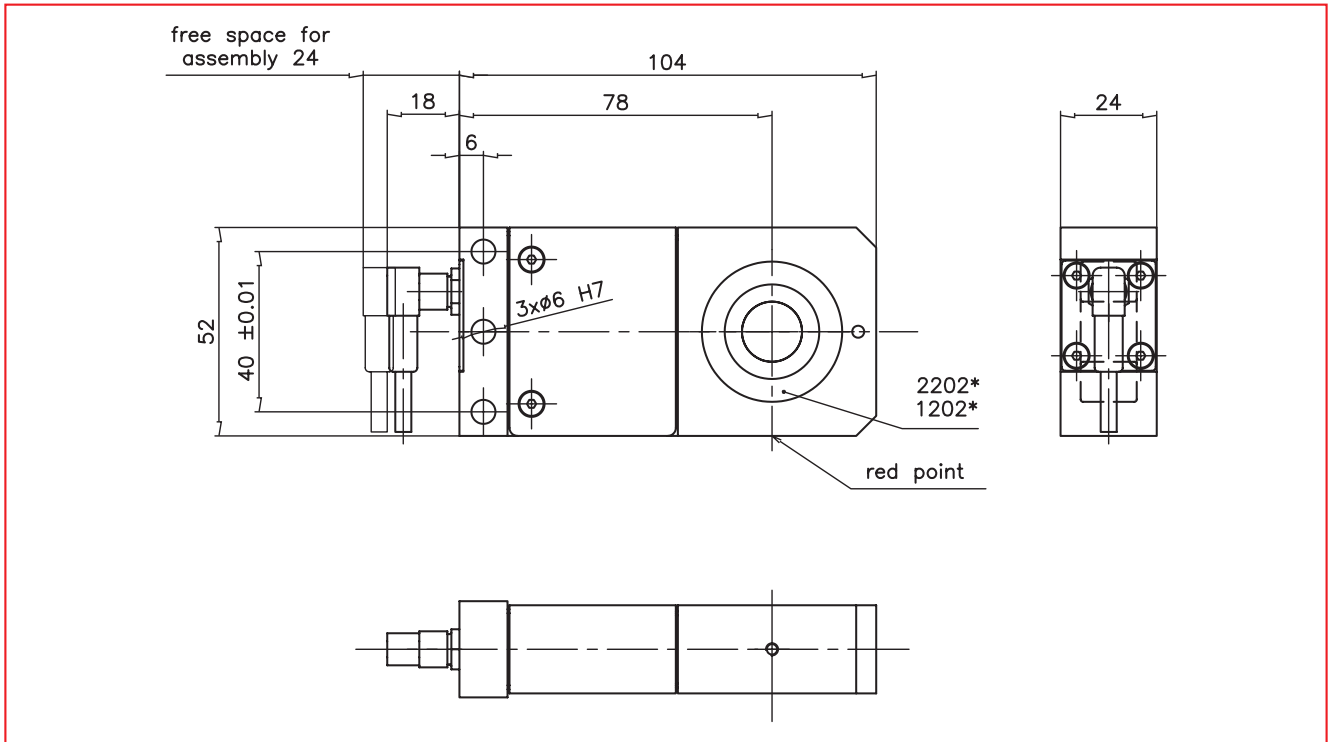

Bearings 1202 TV and 2202 TV are for rollers with 15 mm journal diameter.

F202 Series • Specifications

Sensor Type	Nominal Force		Weight	
	N	lbf	kg	lbs
F202.50	50	11.2	0.64	1.4
F202.125	125	28.1	0.64	1.4
F202.250	250	56.2	0.64	1.4
F202.500	500	112.4	0.64	1.4

Order Code (example):

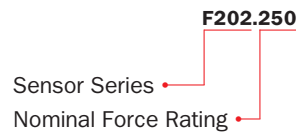

Scope of delivery:

1 Sensor, 1 Snap Ring,
Operation Manual.

Not Included:

Mounting Screws, Washers, Cable,
Connector, or Bearing.

F202 Series • Technical Data

Sensitivity	1.8 mV / V ± 2%
Accuracy Class	± 0.3% (F _{nominal})
Temperature Coefficient	± 0.1% / 10 K
Temperature Range	- 10...+ 60 °C [14...140 °F]
Input Resistance	350 Ω
Supply Voltage	1...12 VDC
Maximum Overload	10-times rated nominal force
Sensor Material	Stainless steel

Accessories F202 Ordering Code

Shoulder bolt ∅ 6 x 30/M5	50001930
Dowel pin d6 h6 x 20	50000558
Sensor cable with connector	50002226 (2 m) 50002227 (10 m)

World Headquarters:

FMS Force Measuring Systems AG
Aspstrasse 6
8154 Oberglatt (Switzerland)
Phone + 41 44 852 80 80
Fax + 41 44 850 60 06
info@fms-technology.com

FMS USA, Inc.
2155 Stonington Avenue
Suite 119
Hoffman Estates, IL 60169
Phone + 1 847 519 4400
Fax + 1 847 519 4401
fmsusa@fms-technology.com

FMS UK
Highfield, Atch Lench Road
Church Lench
Evesham WR 11 4UG
Phone + 44 1386 871023
Fax + 44 1386 871021
fmsuk@fms-technology.com

FMS Italy
Via Baranzate 67
20026 Novate Milanese
Phone + 39 02 39487035
Fax + 39 02 39487035
fmsit@fms-technology.com