

Encoders without bearings - incremental

Magnetic sensing, through hollow shaft max. $\varnothing 740$ mm

512...32768 pulses or 512 sinewave cycles per turn

MHGE 800 - HDmag



MHGE 800 - Version for axial screw mounting

Technical data - electrical ratings

Interference immunity	EN 61000-6-2
Emitted interference	EN 61000-6-3
Approvals	CE, Option: DNV approval

Technical data - electrical ratings (square-wave)

Voltage supply	4.75...30 VDC
Consumption w/o load	≤ 70 mA
Pulses per revolution	512...32768
Phase shift	$90^\circ \pm 10^\circ$
Scan ratio	40...60 %
Reference signal	Zero pulse, width 90°
Sensing method	Magnetic
Output frequency	≤ 300 kHz
Output signals	A+, B+, R+, A-, B-, R-
Output stages	HTL TTL/RS422

Technical data - electrical ratings (SinCos)

Voltage supply	5 VDC
Consumption w/o load	≤ 70 mA
Sinewave cycles per turn	512
Phase shift	$90^\circ \pm 5^\circ$
Reference signal	Zero pulse, width 90°
Sensing method	Magnetic
Output signals	A+, B+, R+, A-, B-, R-
Output stages	SinCos 1 Vpp
Difference of SinCos amplitude	≤ 20 mV
Harmonics typ.	-40 dB
DC offset	≤ 20 mV

Features

- Sinewave or square-wave signals
- Robust and wearless
- High protection through fully encapsulated electronics
- Large tolerances: axial ± 3 mm, radial max. 2.2 mm
- Very compact dimensions
- Simple mounting, easy adaptation

Optional

- DNV approval on request
- Redundant sensing head on request
- Increased operating speed through triple-bandage

Technical data - mechanical design

Sensor head	Standard signal processing
Size (flange)	$\varnothing 813$ mm
Shaft type	$\varnothing 650$...740 mm (through hollow shaft)
Axial tolerance	± 3 mm (wheel/head)
Radial tolerance	0.1...2.2 mm (wheel/head)
Protection DIN EN 60529	IP 67 (head), IP 68 (wheel)
Operating temperature	-40 ... $+100$ °C
Operating speed	≤ 1000 rpm
Resistance	IEC 60068-2-6 Vibration 30 g, 55-2000 Hz IEC 60068-2-27 Shock 300 g, 2 ms
Accuracy of magnetic measure	± 50 "
Connection	Flange connector M23, 12-pin Terminal box

Encoders without bearings - incremental

Magnetic sensing, through hollow shaft max. \varnothing 740 mm

512...32768 pulses or 512 sinewave cycles per turn

MHGE 800 - HDmag

Part number

MHGE 800

	5			N		
--	---	--	--	---	--	--

Connection

- C 1x flange connector M23, tangential 12-pin, male, CCW
- B 1x terminal box with cable gland M20, radial

Pulse number/sinewave cycles - see table

Voltage supply / signals

- S 5 VDC / SinCos
- R 4,75...30 VDC / square-wave (TTL)
- T 5 VDC \pm 5 % / square-wave (TTL)
- H 10...30 VDC / square-wave (HTL)
- U 5...30 VDC / square-wave (5 VDC = TTL / 10...30 VDC = HTL universal)

Mounting type / hollow shaft (\varnothing mm)

Screw mounting
G650, G690, G700, G740

Bandaging

- B Encoder wheel standard bandage
- T Encoder wheel with triple-bandage

Pulse number/sinewave cycles

512	2048	8192	32768
1024	4096	16384	

Sinewave cycles only 512 at SinCos output.

Accessories

Connectors and cables

HEK 8 Sensor cable for encoders

Encoders without bearings - incremental

Magnetic sensing, through hollow shaft max. $\varnothing 740$ mm

512...32768 pulses or 512 sinewave cycles per turn

MHGE 800 - HDmag

Output signals

Version with square-wave signals HTL oder TTL at positive rotating direction

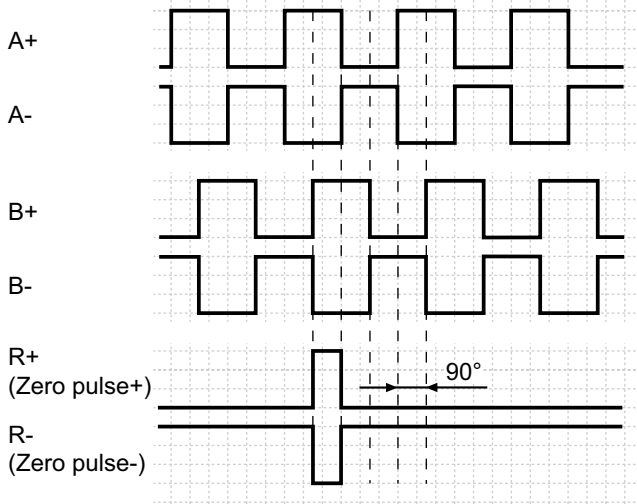

Version with SinCos signals at positive rotating direction

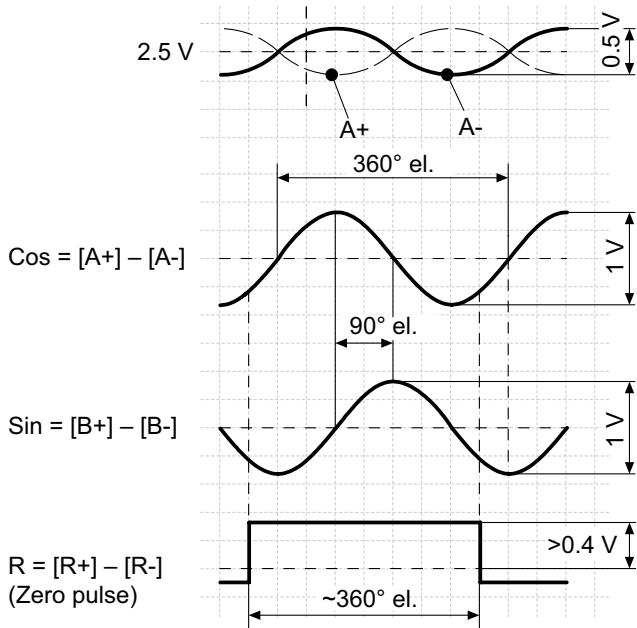

Terminal assignment

View A

Flange connector M23, 12-pin, male contacts, CCW

Pin	Assignment
1	B-
2	Do not use
3	R+ (Zero pulse)
4	R- (Zero pulse inv.)
5	A+
6	A-
7	Do not use
8	B+
9	Do not use
10	⊥
11	Do not use
12	+UB

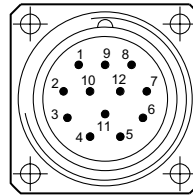

View B

Connecting terminal terminal box

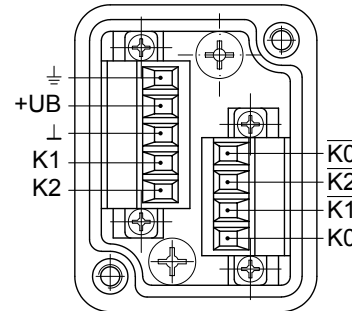

Encoders without bearings - incremental

Magnetic sensing, through hollow shaft max. $\varnothing 740$ mm

512...32768 pulses or 512 sinewave cycles per turn

MHGE 800 - HDmag

Dimensions

Version for axial screw mounting

