

# Encoders without bearings - absolute

Absolute encoder, sensor head with integrated FPGA signal processing

Magnetic sensing, through hollow shaft max.  $\varnothing 340$  mm, singleturn 8...17 Bit

Additional 1...524288 pulses or 1...32768 sinewave cycles per turn

## MHAP 400 - HDmag

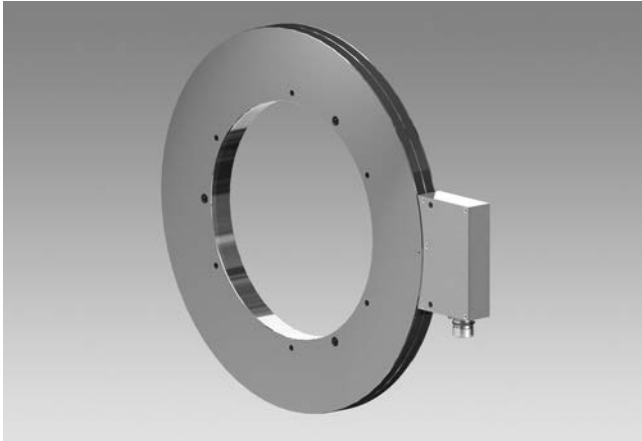

MHAP 400 - Version for axial screw mounting

### Features

- Absolute encoder with magnetic sensing and without bearings
- Sensor head with integrated FPGA signal processing
- Absolute resolution max. 17 bit singleturn
- Additional incremental output
- Robust and wearless
- Electronics is fully encapsulated
- High protection
- Large tolerances: axial  $\pm 1$  mm, radial max. 0.5 mm
- Simple mounting, easy adaptation
- Several mounting possibilities

### Technical data - electrical ratings

Interference immunity	EN 61000-6-2
Emitted interference	EN 61000-6-3
Approval	CE

### Technical data - electrical ratings (SSI)

Voltage supply	4.5...30 VDC
Interface	SSI
Function	Singleturn
Steps per turn	$\leq 131072$ / 17 bit
Sensing method	Magnetic
Code	Gray or binary
Code sequence	CW default
Additional outputs	Square-wave TTL (RS422) Square-wave universal HTL/ TTL SinCos
Interference immunity	EN 61000-6-2
Emitted interference	EN 61000-6-3

### Technical data - electrical ratings (square-wave)

Voltage supply	4.5...30 VDC
Consumption w/o load	$\leq 300$ mA
Pulses per revolution	1...524288
Phase shift	$90^\circ \pm 10^\circ$
Scan ratio	40...60 %
Sensing method	Magnetic
Output frequency	$\leq 2$ MHz
Output signals	A+, A-, B+, B-
Output stages	HTL TTL/RS422

### Technical data - electrical ratings (SinCos)

Voltage supply	4.5...30 VDC
Consumption w/o load	$\leq 300$ mA
Sinewave cycles per turn	1...32768
Phase shift	$90^\circ \pm 5^\circ$
Sensing method	Magnetic
Output signals	A+, A-, B+, B-
Output stages	SinCos 1 Vpp
Difference of SinCos amplitude	$\leq 20$ mV
Harmonics typ.	-40 dB
DC offset	$\leq 20$ mV
Bandwidth	400 kHz (-3 dB)

### Technical data - mechanical design

Sensor head	FPGA signal processing
Size (flange)	$\varnothing 406.8$ mm
Shaft type	$\varnothing 70...340$ mm (through hollow shaft)
Axial tolerance	$\pm 1$ mm (wheel/head)
Radial tolerance	0.1...0.5 mm (wheel/head)
Protection DIN EN 60529	IP 67 (head), IP 68 (wheel)
Operating temperature	-20...+85 °C
Operating speed	$\leq 2000$ rpm
Resistance	IEC 60068-2-6 Vibration 30 g, 55-2000 Hz IEC 60068-2-27 Shock 300 g, 2 ms
Accuracy of magnetic measure	$\pm 150$ "
Connection	Flange connector M23, 17-pin

# Encoders without bearings - absolute

Absolute encoder, sensor head with integrated FPGA signal processing  
 Magnetic sensing, through hollow shaft max.  $\varnothing 340$  mm, singleturn 8...17 Bit  
 Additional 1...524288 pulses or 1...32768 sinewave cycles per turn

MHAP 400 - HDmag

## Part number

MHAP 400 B5 

	S						D
--	---	--	--	--	--	--	---

Pulse number/sinewave cycles - see table

Voltage supply / signals

- P 4.5...30 VDC / SinCos
- R 4.5...30 VDC / square-wave (TTL)
- U 5...30 VDC / square-wave (5 VDC = TTL / 10...30 VDC = HTL universal)
- Z Without additional output signals

Parity bit

- O Odd
- E Even
- N None

Resolution Singleturn (bit)

8, 9, 10, 11, 12, 13, 14, 15, 16, 17

Code

- B Binary code
- G Gray code

Mounting type / hollow shaft ( $\varnothing$  mm)

Screw or shrink fit mounting

G160, G180, G210, G230, G250, G300, G310, G340

Clamping set mounting

Z70, Z75, Z80, Z85, Z90, Z95, Z100, Z110, Z120, Z130, Z140, Z150, Z160

## Pulse number/sinewave cycles

1	16	256	4096	65536
2	32	512	8192	131072
4	64	1024	16384	262144
8	128	2048	32768	524288

Maximum sinewave cycles 32768 for SinCos output.

# Encoders without bearings - absolute

Absolute encoder, sensor head with integrated FPGA signal processing

Magnetic sensing, through hollow shaft max.  $\varnothing 340$  mm, singleturn 8...17 Bit

Additional 1...524288 pulses or 1...32768 sinewave cycles per turn

## MHAP 400 - HDmag

### Data transfer

Without parity bit

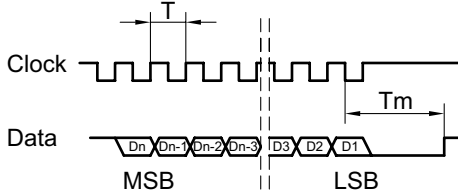

With parity bit

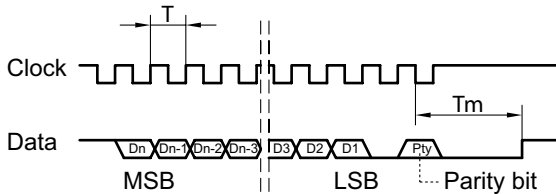

$$T = 0.5 \dots 10 \mu\text{s}$$

$$T_m = 15 \mu\text{s}$$

$$\text{Taktfrequenz} \leq 2 \text{ MHz}$$

### Output signals

Version with additional square-wave signals  
HTL oder TTL at positive rotating direction

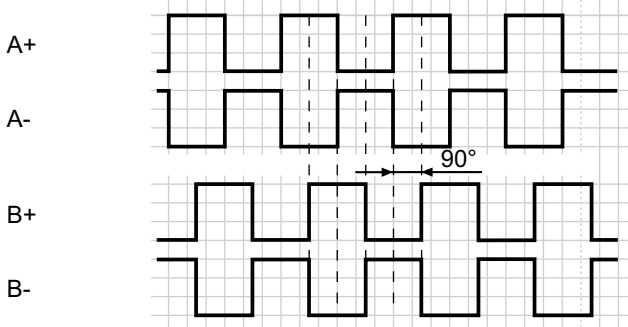

Version with additional SinCos signals  
at positive rotating direction

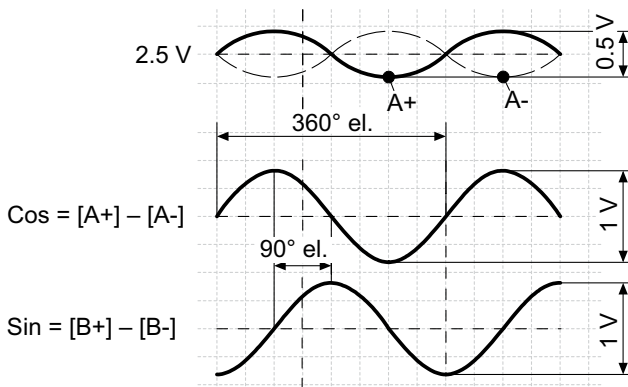

### Terminal assignment

#### View A

Flange connector M23, 17-pin, male, CW

Pin	Assignment
1	Do not use
2	Do not use
3	Do not use
4	Do not use
5	Do not use
6	Do not use
7	+UB
8	SSI Clock+
9	SSI Clock-
10	⊥
11	Internal shield
12	B+ *
13	B- *
14	SSI Data+
15	A+ *
16	A- *
17	SSI Data-

\* Do not use in version without incremental output

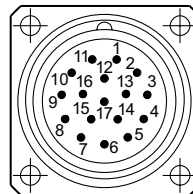

# Encoders without bearings - absolute

Absolute encoder, sensor head with integrated FPGA signal processing

Magnetic sensing, through hollow shaft max.  $\varnothing 340$  mm, singleturn 8...17 Bit

Additional 1...524288 pulses or 1...32768 sinewave cycles per turn

MHAP 400 - HDmag

## Dimensions

### Version for axial screw mounting or shrink fit mounting

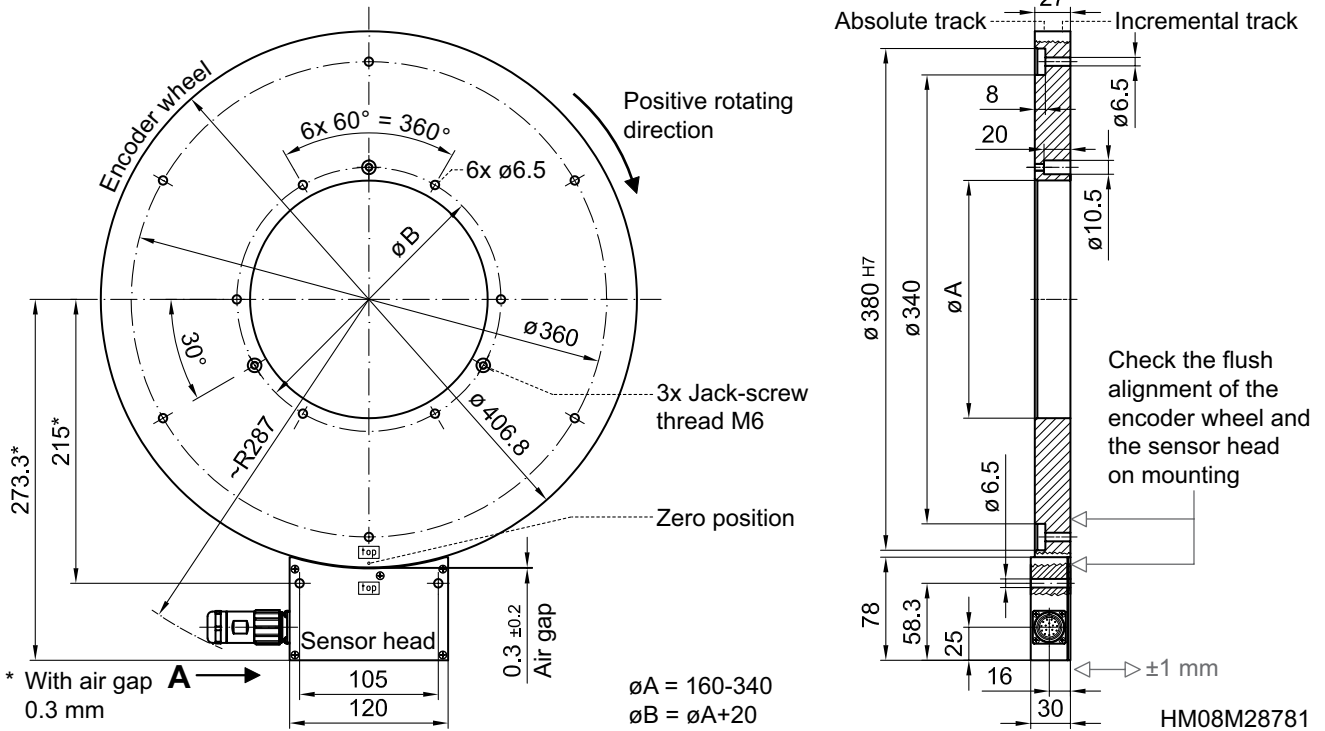

### Version for clamping set mounting

