

Encoders without bearings - absolute

Absolute encoder, sensor head with integrated FPGA signal processing

Magnetic sensing, through hollow shaft max. $\varnothing 180$ mm, singleturn 8...17 Bit

Additional 1...262144 pulses or 1...16384 sinewave cycles per turn

MHAP 200 - HDmag

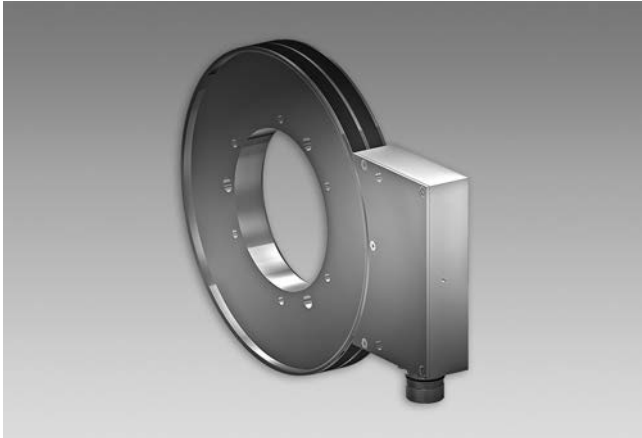

MHAP 200 - Version for axial screw mounting

Features

- Absolute encoder with magnetic sensing and without bearings
- Sensor head with integrated FPGA signal processing
- Absolute resolution max. 17 bit singleturn
- Additional incremental output
- Robust and wearless
- Electronics is fully encapsulated
- High protection
- Large tolerances: axial ± 1 mm, radial max. 0.5 mm
- Simple mounting, easy adaptation
- Several mounting possibilities

Technical data - electrical ratings

Interference immunity	EN 61000-6-2
Emitted interference	EN 61000-6-3
Approval	CE

Technical data - electrical ratings (SSI)

Voltage supply	4.5...30 VDC
Interface	SSI
Function	Singleturn
Steps per turn	≤ 131072 / 17 bit
Sensing method	Magnetic
Code	Gray or binary
Code sequence	CW default
Additional outputs	Square-wave TTL (RS422) Square-wave universal HTL/ TTL SinCos

Technical data - electrical ratings (square-wave)

Voltage supply	4.5...30 VDC
Consumption w/o load	≤ 300 mA
Pulses per revolution	1...262144
Phase shift	$90^\circ \pm 10^\circ$
Scan ratio	40...60 %
Sensing method	Magnetic
Output frequency	≤ 2 MHz
Output signals	A+, A-, B+, B-
Output stages	HTL TTL/RS422

Technical data - electrical ratings (SinCos)

Voltage supply	4.5...30 VDC
Consumption w/o load	≤ 300 mA
Sinewave cycles per turn	1...16384
Phase shift	$90^\circ \pm 5^\circ$
Sensing method	Magnetic
Output signals	A+, A-, B+, B-
Output stages	SinCos 1 Vpp
Difference of SinCos amplitude	≤ 20 mV
Harmonics typ.	-40 dB
DC offset	≤ 20 mV
Bandwidth	400 kHz (-3 dB)

Technical data - mechanical design

Sensor head	FPGA signal processing
Size (flange)	$\varnothing 203.1$ mm
Shaft type	$\varnothing 50...180$ mm (through hollow shaft)
Axial tolerance	± 1 mm (wheel/head)
Radial tolerance	0.1...0.5 mm (wheel/head)
Protection DIN EN 60529	IP 67 (head), IP 68 (wheel)
Operating temperature	-20...+85 °C
Operating speed	≤ 4000 rpm
Resistance	IEC 60068-2-6 Vibration 30 g, 55-2000 Hz IEC 60068-2-27 Shock 300 g, 2 ms
Accuracy of magnetic measure	± 200 "
Connection	Flange connector M23, 17-pin

Encoders without bearings - absolute

Absolute encoder, sensor head with integrated FPGA signal processing
 Magnetic sensing, through hollow shaft max. \varnothing 180 mm, singleturn 8...17 Bit
 Additional 1...262144 pulses or 1...16384 sinewave cycles per turn

MHAP 200 - HDmag

Part number

MHAP 200 B5

	S						D
--	---	--	--	--	--	--	---

Pulse number/sinewave cycles - see table

Voltage supply / signals

P 4.5...30 VDC / SinCos

R 4.5...30 VDC / square-wave (TTL)

U 5...30 VDC / square-wave (5 VDC = TTL / 10...30 VDC = HTL universal)

Z Without additional output signals

Parity bit

O Odd

E Even

N None

Resolution Singleturn (bit)

8, 9, 10, 11, 12, 13, 14, 15, 16, 17

Code

B Binary code

G Gray code

Mounting type / hollow shaft (\varnothing mm)

Screw or shrink fit mounting

G50, G75, G80, G85, G90, G95, G100, G110, G115, G120, G130, G150, G160, G170, G180

Clamping set mounting

Z70, Z75, Z80, Z85, Z90, Z95, Z100, Z110, Z120, Z130, Z140, Z150

Clamping ring mounting

K70, K75, K80, K85, K90, K95, K100, K105, K110, K115, K120, K140, K150

Pulse number/sinewave cycles

1	16	256	4096	65536
2	32	512	8192	131072
4	64	1024	16384	262144
8	128	2048	32768	

Maximum sinewave cycles 16384 for SinCos output.

Encoders without bearings - absolute

Absolute encoder, sensor head with integrated FPGA signal processing

Magnetic sensing, through hollow shaft max. $\varnothing 180$ mm, singleturn 8...17 Bit

Additional 1...262144 pulses or 1...16384 sinewave cycles per turn

MHAP 200 - HDmag

Data transfer

Without parity bit

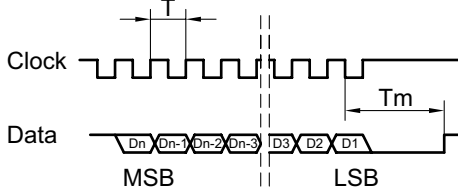

With parity bit

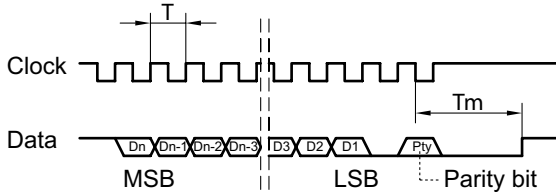

$$T = 0.5 \dots 10 \mu\text{s}$$

$$T_m = 15 \mu\text{s}$$

$$\text{Taktfrequenz} \leq 2 \text{ MHz}$$

Output signals

Version with additional square-wave signals
HTL oder TTL at positive rotating direction

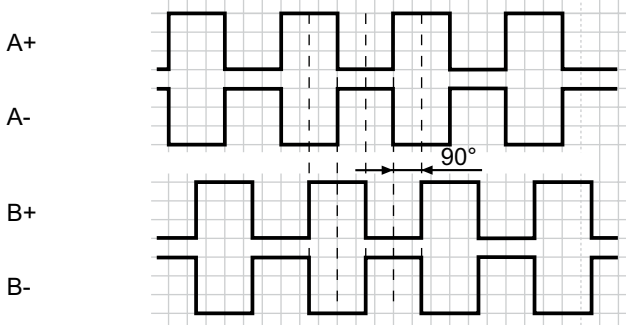

Version with additional SinCos signals
at positive rotating direction

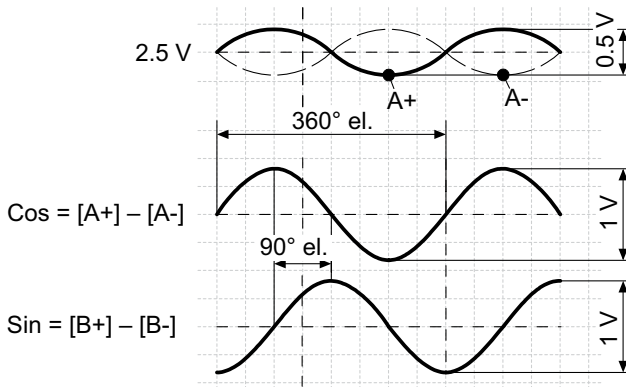

Terminal assignment

View A

Flange connector M23, 17-pin, male, CW

Pin	Assignment
1	Do not use
2	Do not use
3	Do not use
4	Do not use
5	Do not use
6	Do not use
7	+UB
8	SSI Clock+
9	SSI Clock-
10	⊥
11	Internal shield
12	B+ *
13	B- *
14	SSI Data+
15	A+ *
16	A- *
17	SSI Data-

* Do not use in version without incremental output

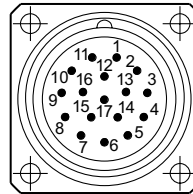

Encoders without bearings - absolute

Absolute encoder, sensor head with integrated FPGA signal processing

Magnetic sensing, through hollow shaft max. $\varnothing 180$ mm, singleturn 8...17 Bit

Additional 1...262144 pulses or 1...16384 sinewave cycles per turn

MHAP 200 - HDmag

Dimensions

Version for axial screw mounting or shrink fit mounting

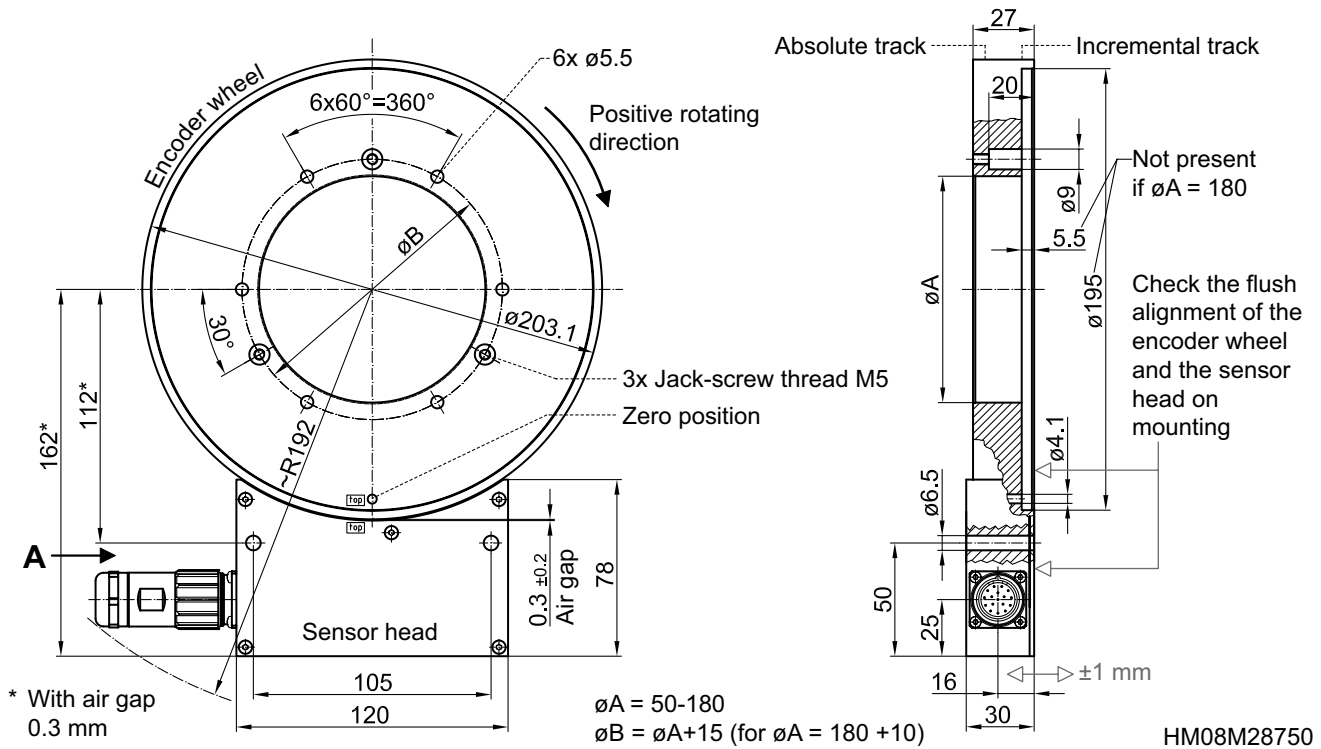

Version for clamping set mounting

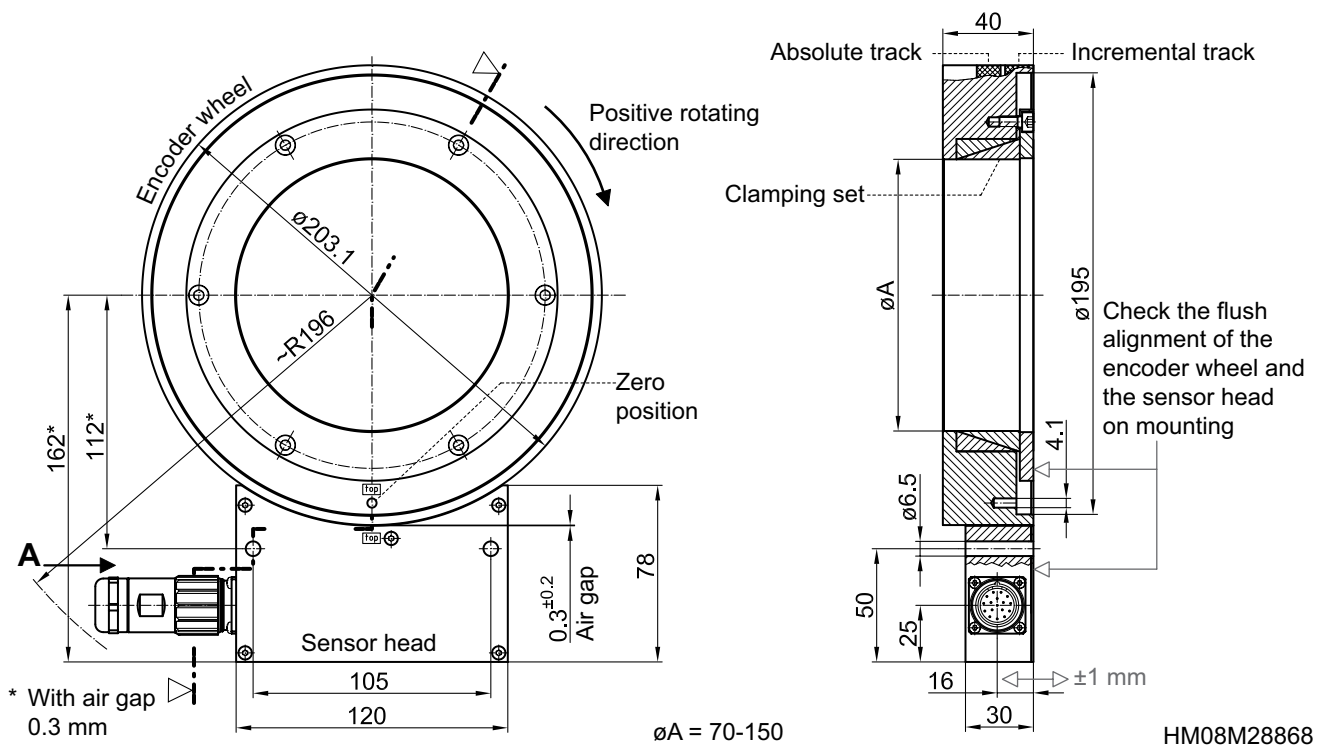

Encoders without bearings - absolute

Absolute encoder, sensor head with integrated FPGA signal processing

Magnetic sensing, through hollow shaft max. $\varnothing 180$ mm, singleturn 8...17 Bit

Additional 1...262144 pulses or 1...16384 sinewave cycles per turn

MHAP 200 - HDmag

Dimensions

Version for clamping ring mounting

