

Incremental encoders

Through hollow shaft up to $\varnothing 75$ mm
1024...5000 pulses per revolution

HOG 14



HOG 14

Features

- Through hollow shaft up to $\varnothing 75$ mm
- Optical sensing method
- Robust light-metal housing
- Output stage HTL or TTL
- Output stage TTL with regulator UB 9...26 VDC

Technical data - electrical ratings

Voltage supply	9...26 VDC 5 VDC ± 5 %
Consumption w/o load	≤ 100 mA
Pulses per revolution	1024...5000
Phase shift	$90^\circ \pm 8^\circ$
Scan ratio	44...56 %
Reference signal	Zero pulse, width 90°
Sensing method	Optical
Output frequency	≤ 250 kHz
Output signals	K1, K2, K0 + inverted
Output stages	HTL TTL/RS422
Interference immunity	EN 61000-6-2
Emitted interference	EN 61000-6-3
Approvals	CE, UL approval / E256710

Technical data - mechanical design

Size (flange)	$\varnothing 158$ mm
Shaft type	$\varnothing 40...75$ mm (through hollow shaft)
Admitted shaft load	≤ 50 N axial ≤ 100 N radial
Protection DIN EN 60529	IP 55
Operating speed	≤ 6300 rpm (mechanical)
Operating torque typ.	15 Ncm
Rotor moment of inertia	16.5 kgcm ² ($\varnothing 70$)
Materials	Housing: aluminium Shaft: stainless steel
Operating temperature	$-30...+85$ °C
Resistance	IEC 60068-2-6 Vibration 10 g, 10-2000 Hz IEC 60068-2-27 Shock 100 g, 6 ms
Explosion protection	II 3 G Ex nA IIC T4 Gc (gas) II 3 D Ex tc IIIB T135°C Dc (dust)
Connection	Terminal box
Weight approx.	2.5 kg

Incremental encoders

Through hollow shaft up to $\varnothing 75$ mm
1024...5000 pulses per revolution

HOG 14

Part number

Incremental encoder

HOG14 **DN**

Shaft diameter

40H7	Through hollow shaft $\varnothing 40$ mm
45H7	Through hollow shaft $\varnothing 45$ mm
48H7	Through hollow shaft $\varnothing 48$ mm
50H7	Through hollow shaft $\varnothing 50$ mm
60H7	Through hollow shaft $\varnothing 60$ mm
70H7	Through hollow shaft $\varnothing 70$ mm
75H7	Through hollow shaft $\varnothing 75$ mm

Voltage supply / signals

CI	9...26 VDC / output stage HTL (C) with inverted signals
TTL	5 VDC / output stage TTL with inverted signals
R	9...26 VDC / output stage TTL with inverted signals

Pulse number - see table

Output signals

DN K1, K2, K0

Pulse number

1024 | 5000

Accessories

Connectors and cables

HEK 8 Sensor cable for encoders

Diagnostic accessories

HENQ 1100 Analyzer for encoders

Incremental encoders

Through hollow shaft up to $\varnothing 75$ mm

1024...5000 pulses per revolution

HOG 14

Output signals

At positive rotating direction

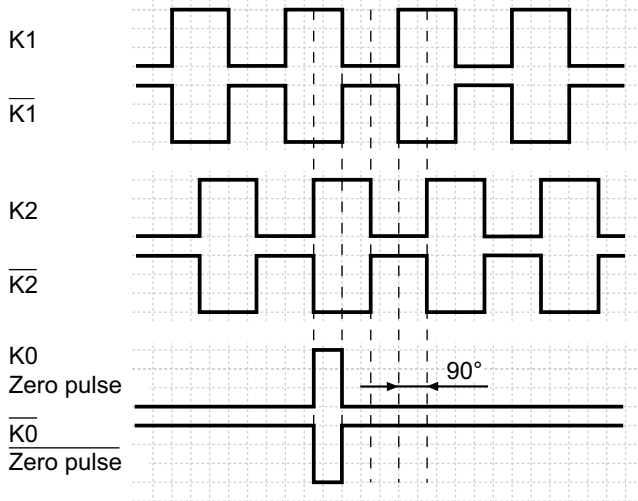

Terminal assignment

View A - Connecting terminal in terminal box

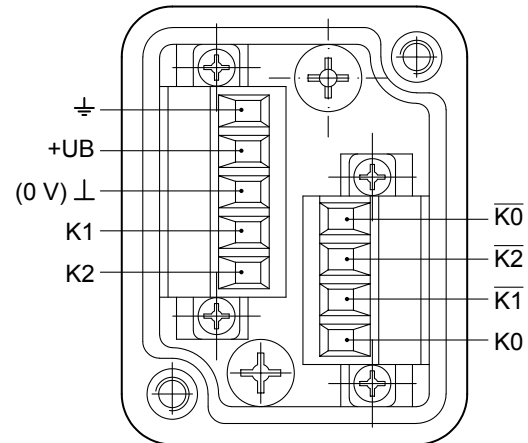

Incremental encoders

Through hollow shaft up to $\varnothing 75$ mm
1024...5000 pulses per revolution

HOG 14

Dimensions

