

# Tachogenerators

Blind hollow shaft  $\varnothing 12-16$  mm or cone shaft  $\varnothing 17$  mm (1:10)

Housing  $\varnothing 95$  mm, bearingless configuration

## GTB 9



GTB 9

### Features

- Low response time
- Open circuit voltage 10...60 mV per rpm
- Blind hollow shaft  $\varnothing 12-16$  mm or cone shaft  $\varnothing 17$  mm (1:10)
- High signal quality due to patented LongLife technology
- High protection IP 68
- Connector output
- No auxiliary energy source required

### Technical data - electrical ratings

Reversal tolerance	$\leq 0.1$ %
Linearity tolerance	$\leq 0.15$ %
Temperature coefficient	$\pm 0.05$ %/K (open-circuit)
Isolation class	B
Calibration tolerance	$\pm 5$ %
Climatic test	Humid heat, constant (IEC 60068-2-3, Ca)
Performance	0.3 W (speed $\geq 5000$ rpm)
Armature-circuit time-constant	$< 9$ $\mu$ s
Interference immunity	EN 61000-6-2
Emitted interference	EN 61000-6-3
Approval	CE

### GTB 9.06

Open-circuit voltage	10...20 mV per rpm
----------------------	--------------------

### GTB 9.16

Open-circuit voltage	60 mV per rpm
----------------------	---------------

### Technical data - mechanical design

Size (flange)	$\varnothing 95$ mm
Shaft type	$\varnothing 12...16$ mm (blind hollow shaft) $\varnothing 17$ mm (cone shaft 1:10)
Protection DIN EN 60529	IP 68
Torque	0.35 Ncm
Rotor moment of inertia	0.95 kgcm <sup>2</sup>
Materials	Housing: stainless steel / plastic Shaft: stainless steel
Operating temperature	-30...+130 °C
Resistance	IEC 60068-2-6 Vibration 10 g, 10-2000 Hz IEC 60068-2-27 Shock 100 g, 6 ms
Weight approx.	0.7 kg
Connection	Connector

# Tachogenerators

Blind hollow shaft  $\varnothing 12-16$  mm or cone shaft  $\varnothing 17$  mm (1:10)

Housing  $\varnothing 95$  mm, bearingless configuration

GTB 9

## Part number

GTB9.06L/4

GTB9.16L/4  60

### Design

- Cylindrical shaft
- K Cone shaft

### Design

- Cylindrical shaft
- K Cone shaft

### Open-circuit voltage

10 10 mV per rpm  
20 20 mV per rpm

### Open-circuit voltage

60 60 mV per rpm

## Data according to type

Type	Off-load voltage $U_0$ [mV/rpm]	Minimum load required depending on speed range [rpm]			Maximum operating speed $n_{max}$ [rpm]	Armature resistance $R_A(20^\circ C)$ [ $\Omega$ ]	Armature inductance $L_A$ [mH]
		0-3000	0-6000	0- $n_{max}$			
GTB9.06L/410	10	$\geq 5$	$\geq 12$	$\geq 27$	9000	105	40
GTB9.06L/420	20	$\geq 20$	$\geq 48$	$\geq 108$	9000	370	169
GTB9.16L/460	60	$\geq 60$	$\geq 144$	-	6000	340	275

Superimposed ripple (for  $\tau_{RC} = 0.3$  ms):  $\leq 0.5\%$  (peak-peak)  $\leq 0.25\%$  (rms)

## Replacement switching diagram

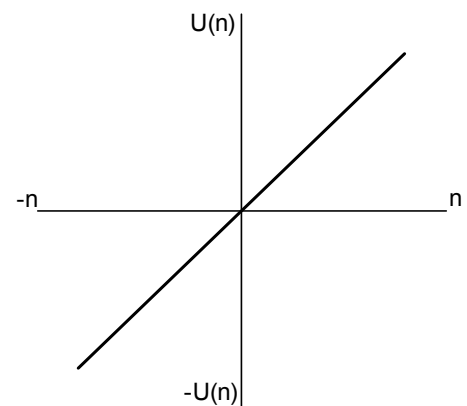
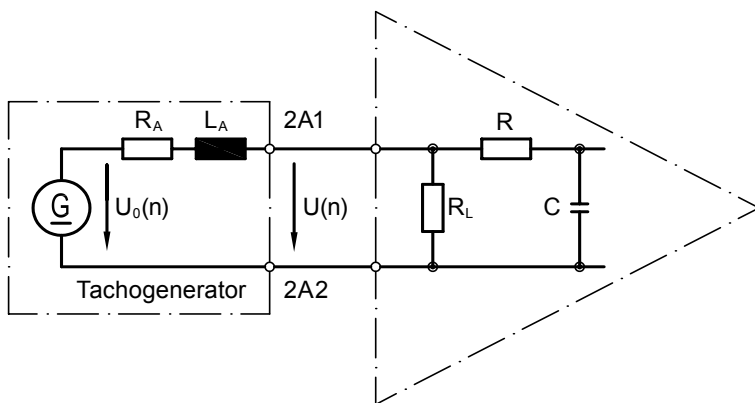

$$\tau_{RC} \approx R \cdot C \quad \tau_A \approx \frac{L_A}{R_L}$$

$$U(n) = U_0(n) \frac{R_L}{R_A + R_L} \approx U_0(n) \text{ for } R > R_L \gg R_A$$

Polarity for positive rotating direction: 2A1: + 2A2: - (VDE)

# Tachogenerators

Blind hollow shaft  $\varnothing 12-16$  mm or cone shaft  $\varnothing 17$  mm (1:10)

Housing  $\varnothing 95$  mm, bearingless configuration

## GTB 9

### Terminal assignment

View A - Connecting terminal

Polarity for positive direction of rotation

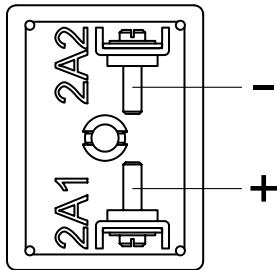

### Accessories

Mounting cone

Carbon brushes

# Tachogenerators

Blind hollow shaft  $\varnothing 12-16$  mm or cone shaft  $\varnothing 17$  mm (1:10)

Housing  $\varnothing 95$  mm, bearingless configuration

GTB 9

## Dimensions

### GTB 9.06 - cylinder shaft design

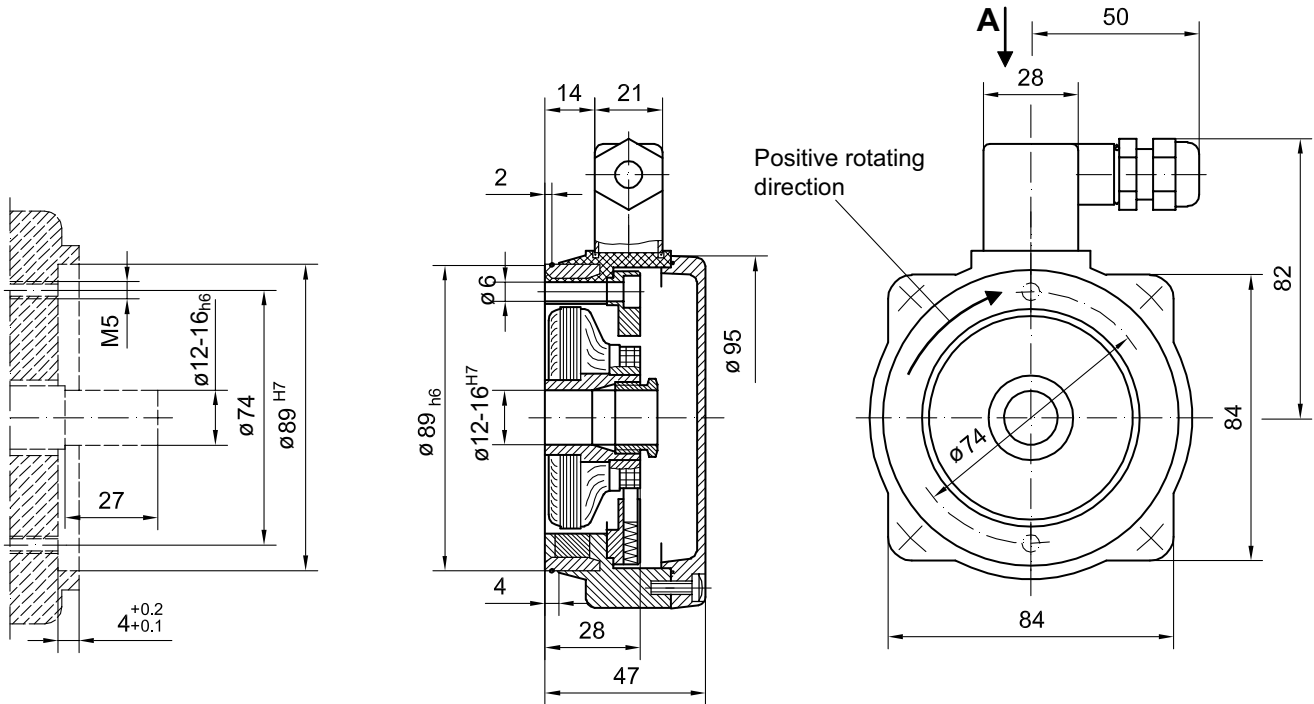

HM85M20491

### GTB 9.06 K - cone shaft design

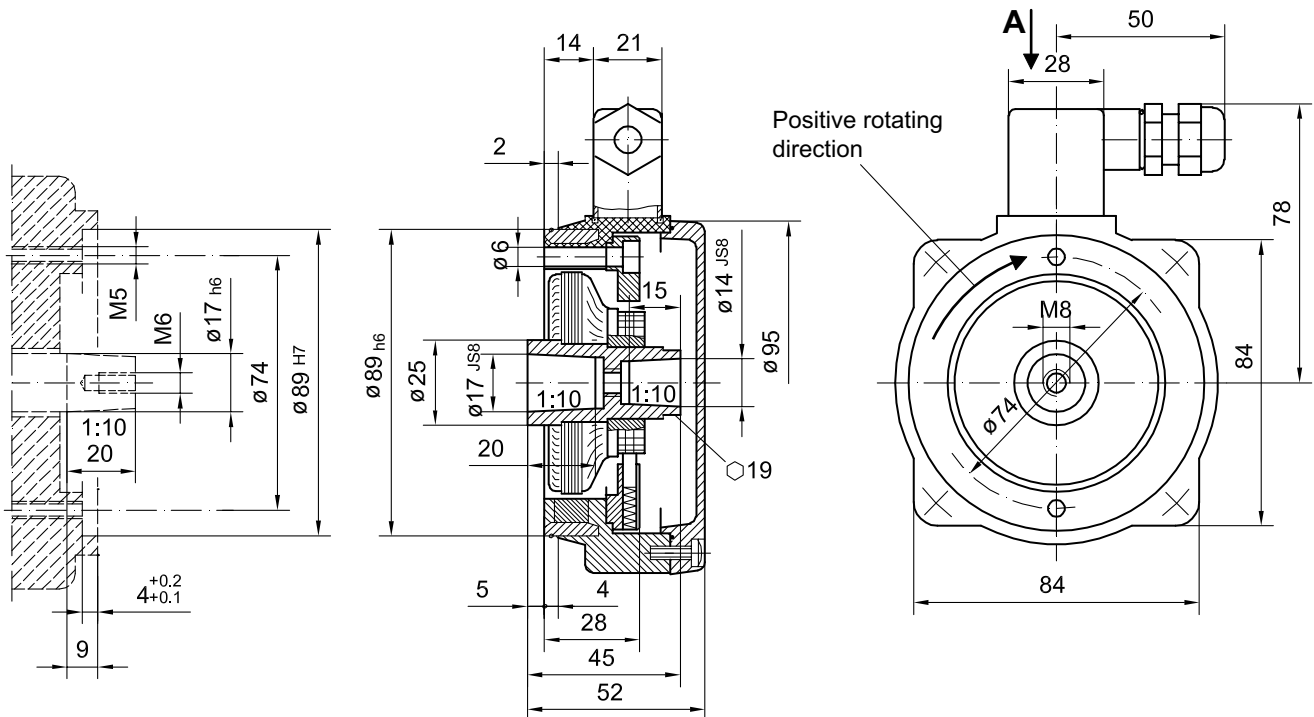

HM85M20484