

# Absolute encoders - bus interfaces

Encoder with solid shaft  $\varnothing 11$  mm and EURO flange B10

Single and multiturn 13 bit ST / 12 or 16 bit MT

SSI / Profibus / CANopen®

## AMG 81



AMG 81 P (C) + incremental

### Features

- Multiturn / SSI / Profibus / CANopen®
- Optical sensing method
- Singleturn 13 bit, multiturn 12 bit / 16 bit
- EURO-flange B10 / solid shaft  $\varnothing 11$  mm

### Optional

- Additional incremental output (TTL / HTL)

### Technical data - electrical ratings

Voltage supply	9...30 VDC
Consumption w/o load	$\leq 100$ mA (per interface SSI) $\leq 250$ mA (per interface bus)
Initializing time	$\leq 200$ ms after power on
Interfaces	SSI, Profibus-DPV0, CANopen®
Function	Multiturn
Transmission rate	9.6...12000 kBaud (Profibus) 10...1000 kBaud (CANopen®)
Profile conformity	Profibus-DPV0 CANopen® CiA DSP 406 V 3.0
Device address	Rotary switches in bus cover
Steps per turn	8192 / 13 bit
Number of turns	4096 / 12 bit, 65536 / 16 bit
Additional outputs	Square-wave TTL (RS422) Square-wave HTL
Incremental output	2048 pulses per revolution
Sensing method	Optical
Code	Gray (version SSI)
Code sequence	CW default
Inputs	SSI clock (version SSI)
Interference immunity	EN 61000-6-2
Emitted interference	EN 61000-6-3
Programmable parameters	Depending on the selected absolute interface
Diagnostic function	Position or parameter error
Status indicator	DUO-LED integrated in bus cover
Approvals	CE, UL approval / E256710

### Technical data - mechanical design

Size (flange)	$\varnothing 115$ mm
Shaft type	$\varnothing 11$ mm solid shaft
Flange	EURO flange B10
Protection DIN EN 60529	IP 55
Operating speed	$\leq 3500$ rpm (mechanical)
Operating torque	$\leq 10$ Ncm
Rotor moment of inertia	1.4 kgcm <sup>2</sup>
Admitted shaft load	$\leq 50$ N axial $\leq 60$ N radial
Materials	Housing: aluminium alloy Shaft: stainless steel
Operating temperature	-20...+85 °C
Resistance	IEC 60068-2-6 Vibration 10 g, 10-2000 Hz IEC 60068-2-27 Shock 100 g, 6 ms
Explosion protection	II 3 G Ex nA IIC T4 Gc (gas) II 3 D Ex tc IIIB T120°C Dc (dust)
Weight approx.	1.7 kg (depending on version)
Connection	Bus cover Flange connector M23, 12-pin (SSI/incremental)

# Absolute encoders - bus interfaces

Encoder with solid shaft  $\varnothing 11$  mm and EURO flange B10  
Single and multiturn 13 bit ST / 12 or 16 bit MT  
SSI / Profibus / CANopen®

AMG 81

## Part number

AMG81

					<u>Additional output</u>
				Z0	Without
				T2048	TTL level, 2048 pulses
				H2048	HTL level, 2048 pulses
					<u>Absolute share</u>
				13	13 bit singleturn
				25	13 bit singleturn + 12 bit multiturn (only S version)
				29	13 bit singleturn + 16 bit multiturn (only P and C version)
					<u>Interface/interfaces</u>
				S	SSI
				P	Profibus
				C	CANopen®

## Accessories

### Connectors and cables

HEK 8	Sensor cable for encoders
-------	---------------------------

### Mounting accessories

K 35	Spring washer coupling for solid shaft $\varnothing 6...12$ mm
------	--

K 50	Spring washer coupling for solid shaft $\varnothing 11...16$ mm
------	---

K 60	Spring washer coupling for solid shaft $\varnothing 11...22$ mm
------	---

### Diagnostic accessories

HENQ 1100	Analyzer for encoders
-----------	-----------------------

# Absolute encoders - bus interfaces

Encoder with solid shaft  $\varnothing 11$  mm and EURO flange B10

Single and multiturn 13 bit ST / 12 or 16 bit MT

SSI / Profibus / CANopen®

## AMG 81

### Terminal assignment - Profibus

View A - Connecting terminal in cover

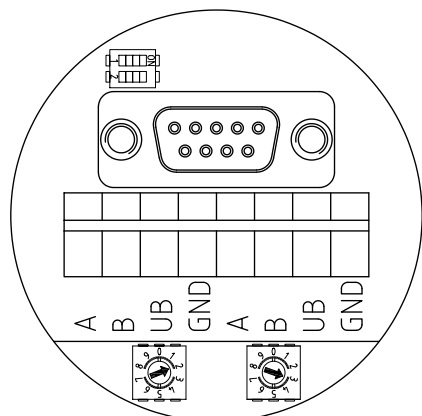

### Terminal significance - Profibus

A	Negative serial data transmission, pair 1 and pair 2
B	Positive serial data transmission, pair 1 and pair 2
UB	Voltage supply 9...30 VDC
GND	Ground connection for UB

Terminals with the same label are internally connected.

### Features - Profibus

Protocol	Profibus DP V0
Profibus features	Device Class 1 and 2
Data Exch. functions	Input: Position value Output: Preset value
Preset value	The „Preset“ parameter can be used to set the encoder to a predefined value that corresponds to a specific axis position of the system.
Parameter functions	Rotating direction: The relationship between the rotating direction and rising or falling output code values can be set in the operating parameter. Scaling: The parameter values set the number of steps per turn and the overall resolution.
Diagnostic	The encoder supports the following error messages: - Position error
Default settings	User address 00

### Terminal assignment - CANopen®

View A - Connecting terminal in cover

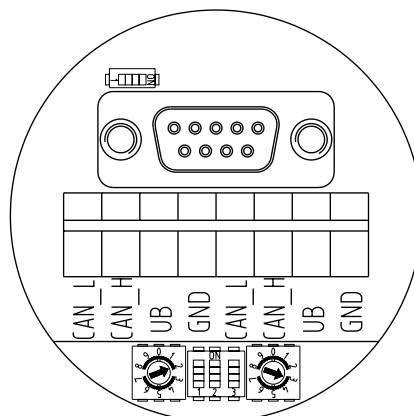

### Terminal significance - CANopen®

CAN_L	CAN Bus signal (dominant low)
CAN_H	CAN Bus signal (dominant high)
UB	Voltage supply 9...30 VDC
GND	Ground connection for UB

Terminals with the same label are internally connected.

### Features - CANopen®

Protocol	CANopen®
CANopen® features	Device class 2 CAN 2.0B
Device profile	CANopen® CiA DSP 406, V 3.0
Operation modes	Polling mode (asynch, via SDO) Cyclic mode (asynch-cyclic) Synch mode (synch-cyclic) Acyclic mode (synch-acyclic)
Diagnostic	The encoder supports the following error messages: - Position error
Default settings	User address 00

# Absolute encoders - bus interfaces

Encoder with solid shaft  $\varnothing 11$  mm and EURO flange B10  
Single and multiturn 13 bit ST / 12 or 16 bit MT  
SSI / Profibus / CANopen®

AMG 81

## Data transfer

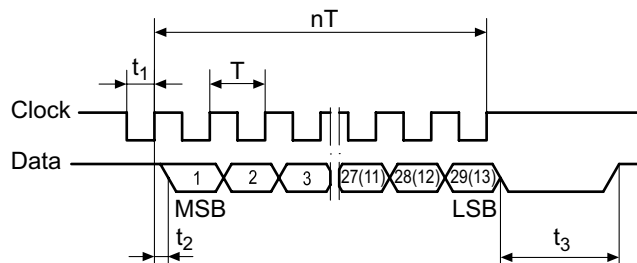

$T$	=	1.25 ... 10 $\mu$ s
$t_1$	=	0.63 ... 5 $\mu$ s
$t_2$	$\leq$	0.4 $\mu$ s
$t_3$	=	12 ... 30 $\mu$ s
$n$	=	Number of bits

Clock frequency	100...800 kHz
-----------------	---------------

## Output signals

Additional incremental signals  
at positive rotating direction

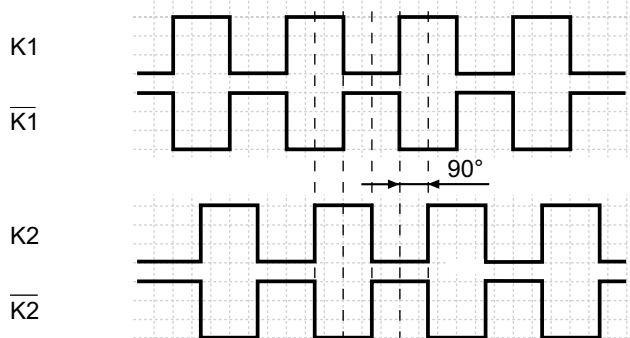

## Terminal assignment

### View B

Connector M23, 12-pin, male contacts, counter-clockwise

Male	Assignment
Pin 1	$\overline{K2}$ (K2 inv.)
Pin 2	Clock *
Pin 3	Data *
Pin 4	$\overline{\text{Data}}$ *
Pin 5	K1
Pin 6	$\overline{K1}$ (K1 inv.)
Pin 7	Param *
Pin 8	K2
Pin 9	$\overline{\text{Error}}$ *
Pin 10	GND
Pin 11	$\overline{\text{Clock}}$ *
Pin 12	+UB

\* only for SSI

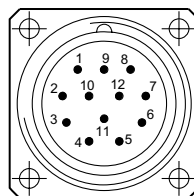

# Absolute encoders - bus interfaces

Encoder with solid shaft  $\varnothing 11$  mm and EURO flange B10

Single and multiturn 13 bit ST / 12 or 16 bit MT

SSI / Profibus / CANopen®

## AMG 81

### Dimensions

#### Version with Profibus or CANopen®

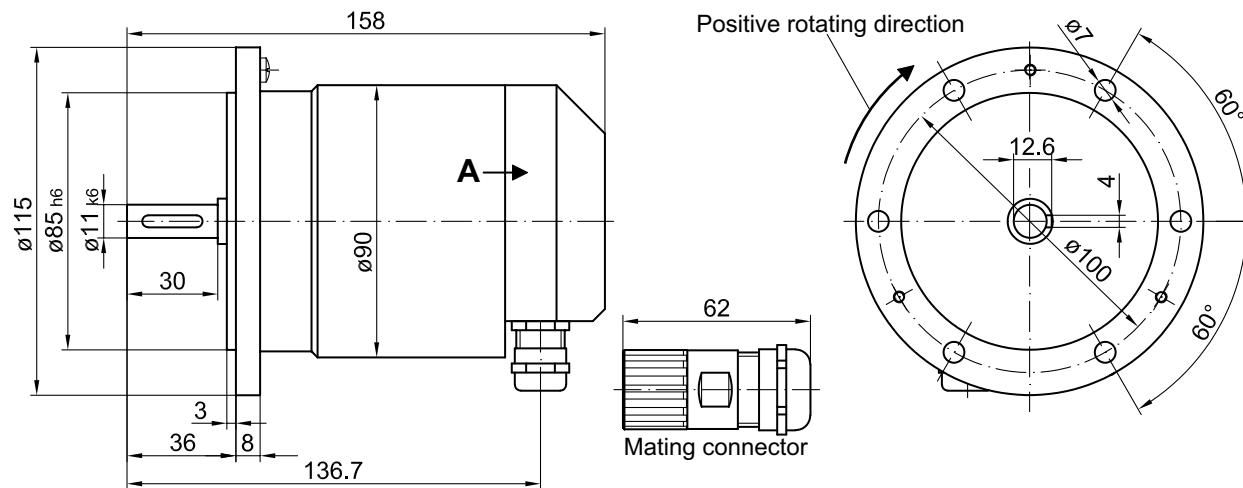

#### Version with SSI and/or incremental

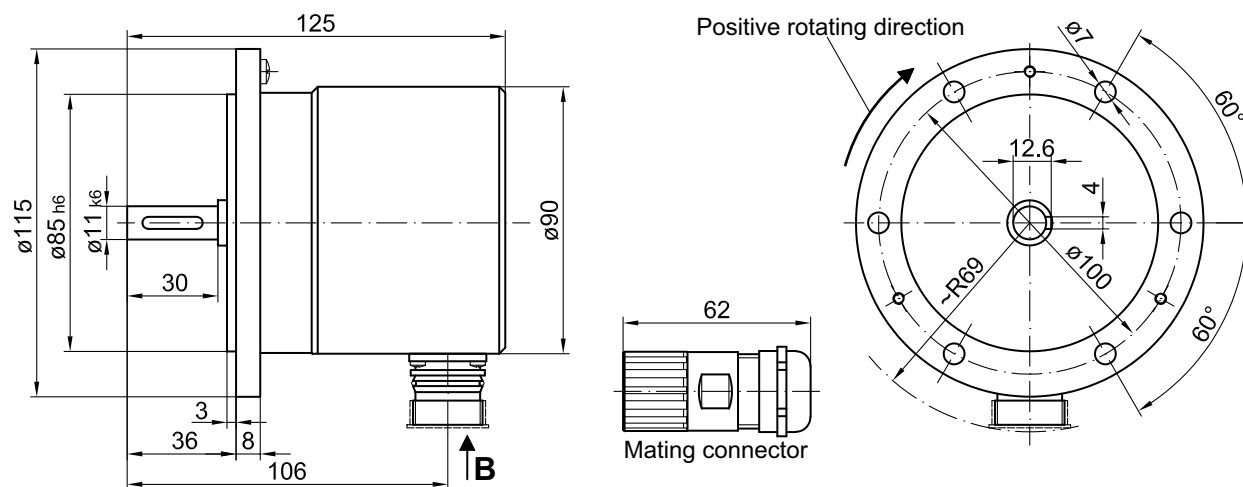

## Version with Profibus or CANopen® and incremental

